

LED WALL PACK

Wall Pack series

LED Lighting System-50,000Hours

Commercial/Architectural Grade

Technology at Word for you

- Architectural UV resistant powder coat finish
- UL&CUL DLC Premium
- System Watts:60W/80W/100W/120W
- Voltages: 100-277Vac/ 200-480Vac
- Efficacy:125lm/W
- Pulsation - less than 5%, THD - less than 25%
- Prismatic glass cover lens
- Operating Humidity: 20% to 90%RH
- Surge Protection:Line-earth 4KV / Line-earth 2KV
- Intelligent Control:Photocell / Motion sensor
- Power Fact(PF) :0.95
- Power Supply Efficiency: > 90%
- Color Temperature: 4000K/4500K/5000K/5700K



5
Years
Warranty



LM-79 LM-80



Features:

- No UV rays, no noise, no flickering, mercury free.
- Instant on/off
- Easy Installation
- Glass optical diffuser, high lumen output,
- Longer life than HPS/MH & HID's
- wide voltage and constant current design
- 50%~80%+ energy savings
- IP65 rated
- 5 Years limited warranty (DLC)

Dimension:

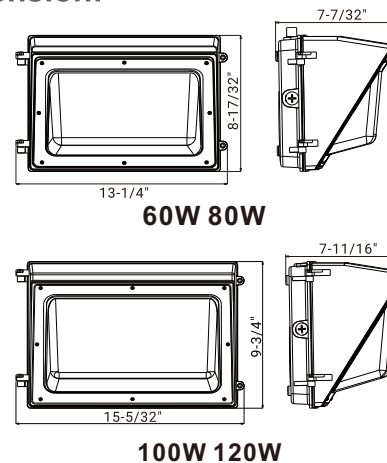

ORDERING INFORMATION

Model No.	Watts	Initial lumens	line voltage supply	color Temperature	Starting Temperature	Replace HID
WP-60W	60W	7500lm	120-277V/200-480V	2700-5700K	-30 °C	180W-200W
WP-80W	80W	10000lm	120-277V/200-480V	2700-5700K	-30 °C	240W-280W
WP-100W	100W	12500lm	120-277V/200-480V	2700-5700K	-30 °C	300W-360W
WP-120W	120W	15000lm	120-277V/200-480V	2700-5700K	-30 °C	360W-400W

LITETRON

Web: www.litetrone.com
Email: pibinc@gmail.com

All right reserved @ LITETRON